



SERVICE BULLETIN No. 06
to all distributors

**Fuel tank indication and fuel management
for Sinus/Virus aircraft family**

INFORMATION ONLY

Please pay attention to the following safety definitions used in this service bulletin:

WARNING! Disregarding the following instruction leads to severe deterioration of flight safety and hazardous situations, including such resulting in serious injury and loss of life.

CAUTION! Disregarding the following instruction leads to serious deterioration of flight safety, may cause serious damage to the aircraft and suspend warranty.

Aircraft affected: sn. 062 onwards

Distributors are to translate this service bulletin into their native language and forward it to all concerned owners in your area immediately.

Please see following page(s) for further details.

Fuel tank indication and fuel management

It has come to our attention that there may be a possibility of fuel starvation and engine shut-downs due to misinterpretation of the fuel indication (new visual fuel indicator type, transparent tube).

To prevent this event in the future from happening again, please refer to the following:

1. The new style fuel level indication with the clear tube indicates 25 liters/per tank at the top end of the tube (2 x 30 liters reservoirs) or 35 liters/ per tank (2 x 50 liters reservoirs). This happens because of wing dihedral. Each tank can therefore accept an additional 5 (15) liters when indicated full in the cockpit WITH 0° WING PITCH and WINGS LEVEL (other attitudes differ this indication). A visual check of the fuel quantity by opening the top cap is essential to ensure the proper fuel quantity. In flight, flying in a sideslip will also yield wrong indications!
2. The unusable fuel per 30 liter tank is 2 liters, 5 liters per 50 liter tank . (Pilot and Maintenance manual Page 61)
3. Models with the Rotax 912 feature a return fuel line, connected to the left tank. This implies that proper management of fuel in flight is important so as to assure no fuel loss. The procedure recommended is to close right tank fuel valve by 1/2 in cruise flight. This will provide equal flow from both reservoirs.
4. The Brauniger MFD Fuel Flow indication is not entirely accurate due to the single fuel flow meter usage. Although the meter is calibrated to take the return flow into account but may not be entirely accurate in certain conditions. Regard the fuel status indication of the Brauniger as orientative. Also make sure you input the correct fuel quantity into the Brauniger after each refueling.

Recommendations

- The average fuel flow of Sinus with Rotax 912, based on experience is approximately 9.5 l/hr.
- The average fuel flow of Virus with Rotax 912, based on experience is approximately 11.5 l/hr.
- During climb at max power the fuel consumption is increased. Longer climb-outs will yield higher average fuel consumption.
- A safer approach to fuel consumption is to perform all flight planning calculations with a 11 l/hr consumption (Sinus) and 13 l/h consumption (Virus).
- ALWAYS REMEMBER THAT THE USABLE FUEL IS 56 LITERS FOR THE 60 LITERS VERSION (2+2 liters unusable), 90 LITERS FOR THE 100 LITERS VERSION (5+5 liters unusable).
- ALWAYS PLAN YOUR FLIGHTS WITH A 30 MIN FUEL RESERVE i.e. 6 L (Minimum).
- Other than Standard atmospheric conditions might have a negative effect in fuel consumption.
- TAKE OFF AND LANDING IS TO BE PERFORMED WITH BOTH FUEL VALVES OPEN.
- After having established cruise flight, close the right fuel valve by $\frac{1}{2}$. This will provide for equal fuel flow from both reservoirs, compensating for the return flow into the left fuel tank. IN CRUISE THE SITUATION IN THE WITH THE FUEL VALVES SHOULD BE: LEFT – FULL OPEN, RIGHT – $\frac{1}{2}$ OPEN.
- Before longer cross country flight check the fuel quantity at the top wing filler neck opening to verify the fuel status.

Practical guidelines for refueling

The below data are valid when the aircraft is in 0° deg pitch position (water line) and wings level. Other attitudes may change the indication severely, especially if wings are not level.

Standard, 30 liter fuel tank:

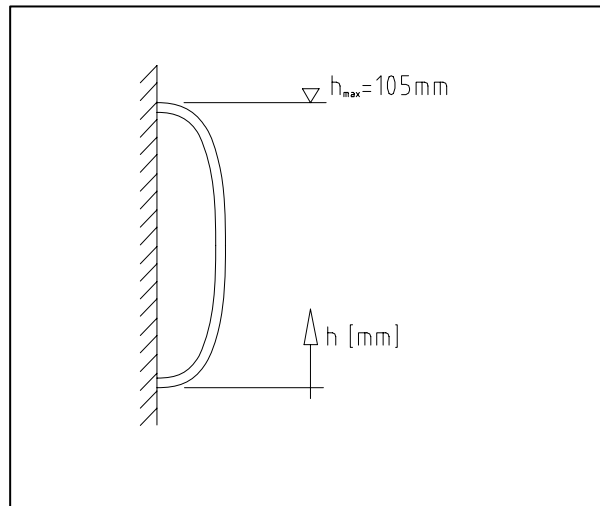

Fuel QTY (liters)	Fuel mass [kg]	Height on ind. tube [mm]
5	3.6	33
10	7.2	51
15	10.8	68
20	14.4	85
25	18.0	105
30	21.6	OFFSCALE HIGH

Long range, 50 liter fuel tank:

Fuel QTY [liters]	Fuel mass [kg]	Height on ind. tube [mm]
5	3,6	38
10	7,2	51
15	10,8	62
20	14,4	73
25	18	81
30	21,6	92
35	25,2	10,5
40	28,8	OFFSCALE HIGH
45	32,4	OFFSCALE HIGH
50	36	OFFSCALE HIGH

Distributors

As a distributor you are to advise each owner about this topic.

Pipistrel d.o.o. Ajdovscina
Ivo Boscarol, GM

THIS IS THE END OF THE SERVICE BULLETIN.
Please confirm reception by e-mail: pipistrel@siol.net