



SB 09

SERVICE BULLETIN No. 09

to all distributors, owners

Brake pad wear and condition for replacement

INFORMATION ONLY

Please pay attention to the following safety definitions used in this service bulletin:

WARNING! Disregarding the following instruction leads to severe deterioration of flight safety and hazardous situations, including such resulting in serious injury and loss of life.

CAUTION! Disregarding the following instruction leads to serious deterioration of flight safety, may cause serious damage to the aircraft and suspend warranty.

Applies to all Sinus/Virus aircraft.

Distributors are to translate this service bulletin into their native language and forward it to all concerned owners in your area immediately.

Please see following page(s) for further details.

Brake pad wear and condition for replacement

Required actions upon periodic maintenance check-up

Check the thickness of the brake pads in both main wheels of the undercarriage. Brake pad thickness is critical for adequate braking action and integrity of the system.

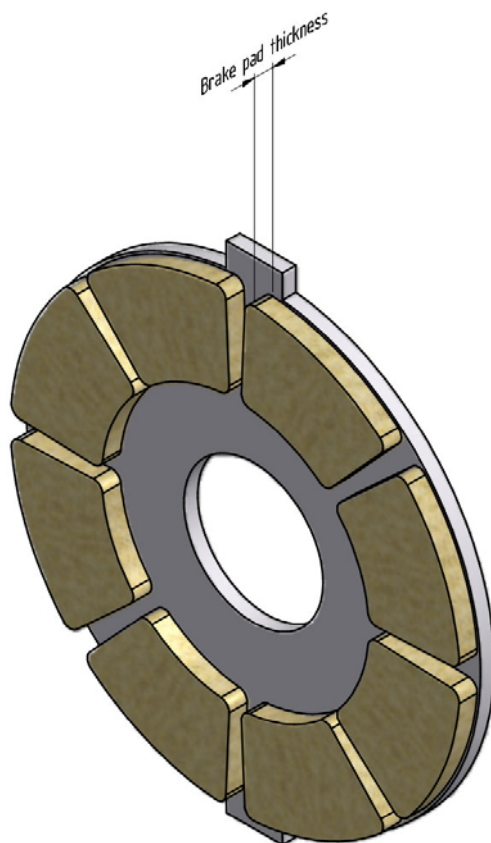

The minimum recommended brake pad thickness for normal brake operation is 2 mm. The absolute minimum brake pad thickness is 1.5 mm. Should the actual brake pad thickness be less, replace the brake-pad with a new part immediately.

WARNING! Worn-out brake-pads will degrade braking action and/or cause the wheel brakes to fail completely.

Distributors

As a distributor you are to advise each concerned owner about this topic.

Pipistrel d.o.o. Ajdovscina
Ivo Boscarol, GM

THIS IS THE END OF THE SERVICE BULLETIN.